

## INSTALLATION & OPERATING INSTRUCTIONS

### COMMERCIAL PUMPS

#### SERIES 4302 & 4382 *dualArm* VERTICAL IN - LINE PUMP

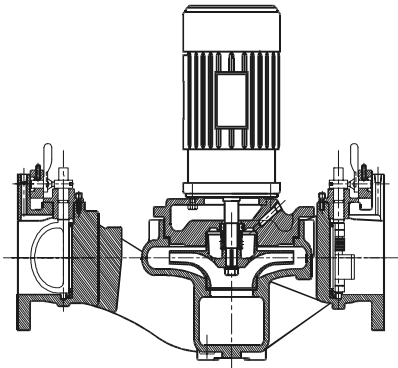

Series 4382 4" *dualArm* illustrated

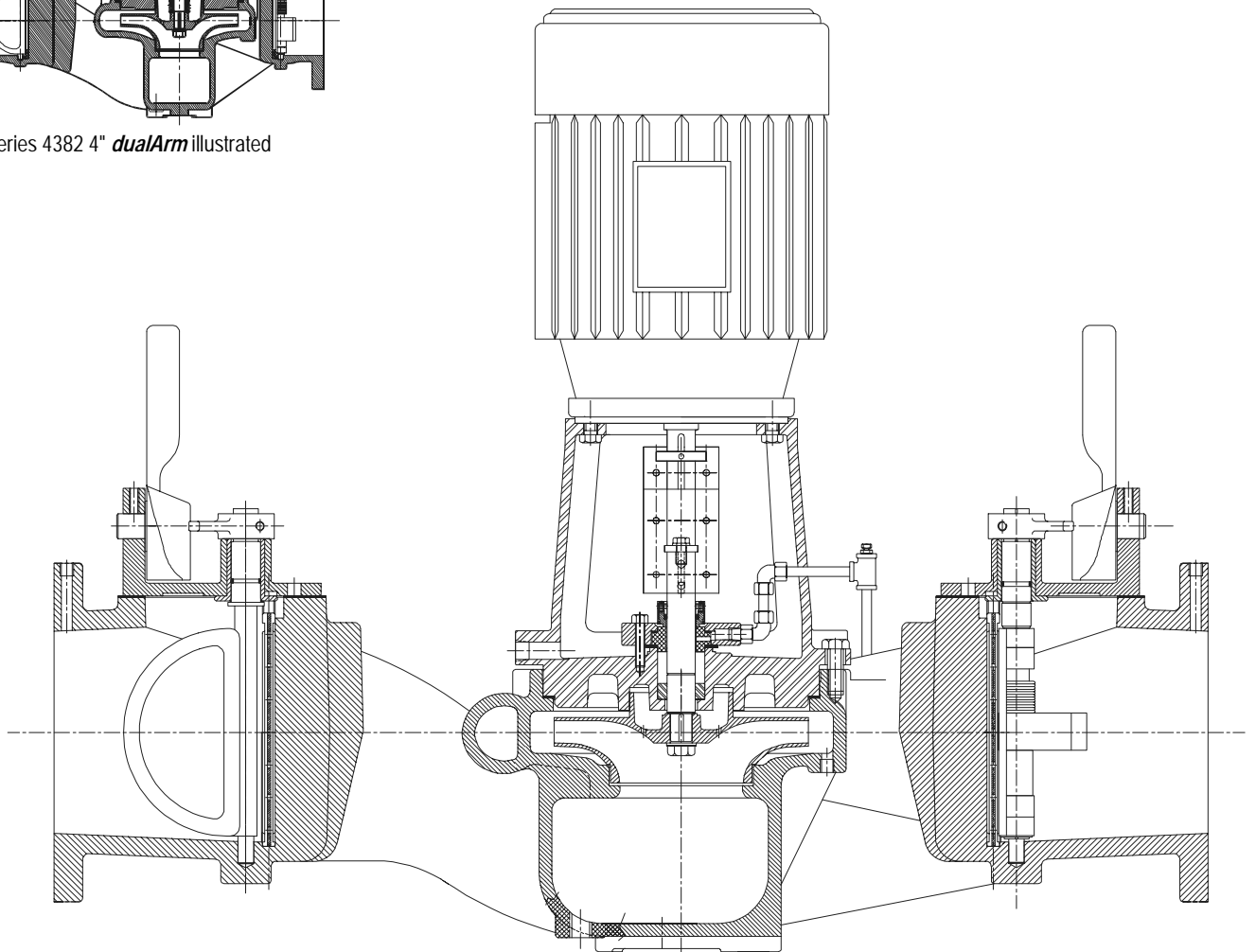

Series 4302 8" *dualArm* illustrated

## UNCRATING

Armstrong *dualArm* in-line pumps are thoroughly inspected before shipment to assure they meet with your order requirements. After removing the pump from the crate, make sure the equipment is in good order and that all components are received as called for on the packing list. Any shortages or damage should be reported immediately. Use extreme care in handling the unit, placing slings carefully so that stress will not be imposed on the pump. NEVER PLACE CABLE SLINGS AROUND THE PUMP SHAFT. The eye bolts or lifting lugs on the motor are intended for lifting only the motor and not the complete unit.

## INSTALLATION - *dualArm* VERTICAL IN-LINE PUMP

### 1. LOCATION

- Locate the unit as close as practical to the liquid being pumped, with a short, direct suction pipe. Ensure adequate space is left above and around the unit for operation, maintenance, service and inspection of parts.
- Electric motor driven pumps should not be located in damp or dusty location without special protection.

### 2. STORAGE

- Pumps not immediately placed into service, or removed from service and stored, must be properly prepared to prevent rusting
- Rotate the shaft periodically to keep rotating element free.
- For long term storage, the pump must be placed in a vertical position in a dry environment.
- Internal rusting can be prevented by removing the plugs at the top and bottom of the casing and drain or air blow out all water to prevent rust build up or the possibility of freezing. Be sure to reinstall the plugs when the unit is made operational. Rustproofing or packing the casing with moisture absorbing material and covering the flanges is acceptable. When returning to service be sure to remove the drying agent from the pump.

### 3. INSTALLATION

- The most important consideration when installing a *dualArm* pump is to make sure the pump is free to 'float' with expansion and contraction of the piping. Recommended arrangements are:
- Piping supported at ceiling with additional floor mounted supports under Armstrong Suction Guide and Flo-Trex Valve (Fig. 1 see back page)
- Supported from the ceiling by pipe hangers (Fig. 2 see back page).
- Floor mounted saddle supports (Fig. 3 see back page)
- Where required, additional floor support may be obtained as shown in Fig. 4. Note that the pump must not be rigidly attached either to the plate or to the block. Leave a 1/8" gap between pump and base. The piping must be installed in such a manner that the pump is not used as a pipe support.
- DO NOT support the unit by the motor eye bolts (Fig. 5 see back page) or by any other part of the motor.

- DO NOT rigidly connect the pump to a permanent base (Fig.6 see back page) Note: if the pump must be connected to a permanent base, the pump must be isolated from the piping by flexible connectors and the base isolated from the building structure on an inertia base.
- DO NOT install the unit with the shaft horizontal.

### 4. PUMP PIPING - GENERAL

- Never connect a pump to piping, always start piping from pump.
- Use as few bends as possible and preferably long radius elbows.
- Do not use flexible connectors on the suction or discharge.
- Make sure piping exerts no strain on pump as this would distort the casing and cause pump misalignment.
- Suction and discharge pipes may be increased at pump nozzle to suit pump capacity and particular conditions of installation. Use eccentric reducers on suction connection.
- Lay out the suction line with a continual rise towards the pump without high points, thus eliminating possibility of air pockets that may prevent the pump from operating.
- A strainer of three or four times the area of the suction pipe, installed in the suction line, will prevent the entrance of foreign materials into the pump. 1/8" (3mm) diameter perforations in the strainer are typical.
- Test suction line for air leaks before starting; this becomes essential with long suction line or static lift.
- Install, at pump suction, a straight pipe of a length equivalent to 4 or 6 times its diameter; this becomes essential when handling liquids above 120°F (49°C). Armstrong suction guides may be used in place of the straight pipe run and in line strainer.
- Install isolation valve in both suction and discharge lines on flooded suction application; this valve is used mainly to isolate the pump for inspection or repair.

#### CAUTION

Discharge valve only must be used to reduce the pump flow, not the suction valve. Care must be taken in the suction line layout and installation, as it is usually the major source of concern in centrifugal pump applications.

- Install a non-slam check valve in discharge line between pump and isolation valve to protect pump from excessive back pressure and to prevent water running back through the pump in case of driver failure. Armstrong Flo-Trex valve may be used in place of check valve and isolation valve on pump discharge.

### 5. ALIGNMENT

- The pumping unit is accurately aligned at the factory prior to being shipped.
- Alignment on the 4302 *dualArm* may be verified by assuring an equal gap between coupling halves on both sides of the coupling.

### IMPORTANT

Do not run the pump for any length of time under very low flow conditions or with the discharge valve closed. To do so could cause the water in the casing to reach super heated steam conditions and will cause premature failure and could cause serious and dramatic damage to the pump and surrounding area.

### OPERATION - *dualArm* VERTICAL IN - LINE PUMP

#### 6. STARTING PUMP

- The pump must be fully primed on start up. Fill the pump casing with liquid and rotate the shaft by hand to remove any air trapped in the impeller. Air trapped in the casing of series 4302 must be removed by the manual air vent in the seal flush line. Air in the 4382 casing is automatically removed through the vent/flush tubing.
- "Bump" or energize the motor for a fraction of a second and check that the rotation corresponds with the directional arrow on the pump casing.
- To reverse rotation of a three phase motor, interchange any two power leads.

### CAUTION

Centrifugal pump rotation is generally "clockwise" when viewing from the motor end.

Check rotation arrow prior to operating the unit

- Start the pump with the discharge valve closed and the suction valve open, then gradually open the discharge valve when the motor is at operating speed. The discharge valve may be "cracked" or open slightly at start up to help eliminate trapped air.
- When stopping the pump: Close the discharge valve and de-energize the motor.

#### 7. GENERAL CARE

- Vertical In-Line pumps are built to operate without periodic maintenance. A systematic inspection made at regular intervals, will ensure years of trouble-free operation, giving special attention to the following;
- Keep unit clean
- Provide the motor with correctly sized overload protection
- Keep moisture, refuse, dust or other loose particles away from the pump and ventilating openings of the motor.

### WARNING

Whenever any service work is to be performed on pumping unit, disconnect power source to driver. Any possibility of the unit starting while being worked on, must be eliminated.

- Avoid operating the unit in overheated surroundings (Above 100°F [40 °C]).
- If mechanical seal environmental accessories are installed, ensure water is flowing through the sight flow indicator and that filter cartridges are replaced as recommended. (See file 43.85 & 43.86 for seal environmental instructions).

#### 8. LUBRICATION

##### PUMP

- Lubrication is not required. There are no bearings in the pump.

##### MOTOR

- Follow the lubrication procedures recommended by the motor manufacturer. Many small and medium sized motors are permanently lubricated.
- Check the lubrication instructions supplied with the motor for the particular frame size indicated on the motor nameplate.

##### MECHANICAL SEAL

- Mechanical seals require no special attention. The mechanical seal is flushed from discharge of the pump casing on 4302 and towards the suction on series 4382. Seal environmental controls, installed in series 4302 flush lines, such as filters and separators, will prolong seal life in hvac systems.
- Do not run the pump unless properly filled with water as the mechanical seals need a film of liquid between the faces for proper operation. (See file 43d.88 for mechanical seal replacement instructions)

#### 9. SYSTEM CLEANLINESS

- Before starting the pump the system must be thoroughly cleaned, flushed and drained and replenished with clean liquid.
- Welding slag and other foreign materials, "Stop Leak" and cleaning compounds and improper or excessive water treatment are all detrimental to the pump internals and sealing arrangement.
- Proper operation cannot be guaranteed if the above conditions are not adhered to.

### NOTE

Particular care must be taken to check the following before the pump is put into operation:

- |                                  |                                      |
|----------------------------------|--------------------------------------|
| A. Pump primed?                  | F. Voltage supply OK?                |
| B. Alignment correct?            | G. Overload protection OK?           |
| C. Rotation OK?                  | H. Is the system clean?              |
| D. Lubrication OK?               | I. Is the area around the pump clean |
| E. Pipe work properly supported? | J. Pipe work properly supported?     |

### WARRANTY

Refer to Armstrong General Terms and Warranty sheet.  
Contact your local Armstrong representative for full information.

## ARMSTRONG *dualArm* PUMP FLAPPER VALVE OPERATING INSTRUCTIONS

This *dualArm* unit is fitted with internal valves to allow isolation of one pump for service and to automatically prevent recirculation of the flow when only one pump is running.

### PROCEDURE FOR PARALLEL OR STAND-BY PUMPING

Discharge and suction valve stems should be locked in the center position. This is indicated by both locking handles in the vertical position and the center pin of the locking arms (4) locked by the handles. This procedure allows the discharge flapper valves to pivot freely and locks the suction valve firmly in the center position.

### PROCEDURE FOR ISOLATION OF ONE SIDE

1. Stop the pump to be serviced.
2. Close and lock the suction and discharge valves: as per instructions below.
3. Ensure seal flushline interconnection valve is closed and drain the isolated casing.
4. Service isolated pump as required.

### PROCEDURE FOR STARTING THE PUMP AFTER SERVICING

1. Ensure serviced pump is fully re-assembled including all seal flush lines and drain plugs.
2. Fill the dry casing with system fluid by opening the seal flushline interconnecting valve and the air vent fitting.
3. Allow the pressure to equalize in the two casings, if necessary, by opening seal flush line interconnected valve.
4. Unlock the discharge valve as per instructions below.
5. Unlock the suction valve as per instructions below.

#### NOTE

KEEP HANDS AND TOOLS AWAY FROM LOCKED SUCTION VALVE ARM, AS THE DIFFERENTIAL PRESSURE MAY CAUSE THE ARM TO ROTATE QUICKLY WITH FORCE WHEN UNLOCKED.

6. Close the seal flushline interconnect valve and restart pump.

**VALVE OPERATION - Refer To Valve Illustration On Page 6 (3", 4" & 6" Valve) Or Page 7 (8" Valve)**

### DISCHARGE VALVE

This valve performs the *dual* function of automatically sealing the discharge of the inactive pump when one pump is running and can manually be closed and locked to isolate one pump for service.

## AUTOMATIC FLAPPER OPERATION

In the flapper mode the two halves of the discharge valve are free to pivot independently under normal operating conditions. The locking handle (3) should be secured with the set screw (11) in the vertical position with the center pin of the locking arm (4) trapped by the locking handle (3).

### MANUAL VALVE LOCKING

The locking feature of this valve is to ensure a positive seal (leak proof) of the discharge port on the pump to be serviced.

#### LOCKING:

#### NOTE

ENSURE THE PUMP TO BE ISOLATED IS NOT OPERATING BEFORE ATTEMPTING TO RELEASE THE LOCKING MECHANISM. FAILURE TO DO SO MAY RESULT IN INJURY TO THE OPERATOR AND/OR DAMAGE TO THE PUMP.

1. Loosen discharge side set screw (11) to release the locking handle (3).
2. Rotate the discharge side locking handle (3) so that the handle points toward the pump to be serviced and secure in the horizontal position, using set screw (11). This releases the discharge locking arm (4).
3. Rotate discharge valve shaft (16) towards the pump to be isolated. The orientation of the shaft is indicated by the center pin on the locking arm (4).
4. Raise the locking handle (3) so that the cam on the base of the handle forces the pin of the locking arm (4) towards the pump to be isolated. The locking handle (3) should be raised to between 45 degrees and the vertical position.
5. Tighten set screw (11) to lock the locking handle (3) in position.

**THIS HANDLE SHOULD NOT BE ROTATED PAST THE VERTICAL POSITION.**

#### UNLOCKING:

#### NOTE

ENSURE THE ISOLATED PUMP IS NOT OPERATING BEFORE ATTEMPTING TO RELEASE THE LOCKING MECHANISM. FAILURE TO DO SO MAY RESULT IN INJURY TO THE OPERATOR AND/OR DAMAGE TO THE PUMP.

1. Open the interconnecting valve on the seal flushline to pressurize the serviced pump and vent air through bleeder valve on series 4302. Close these valves once the pressure is equalized and air removed.

2. Loosen set screw (11) and lower locking handle (3) to the horizontal position, secure with set screw (11).
3. Rotate valve to center position so that the center pin of the locking arm (4) locates in the recess on the locking handle (3).
4. Loosen set screw (11) and raise locking arm (3) to the vertical position, locking the center pin in the locking arm recess, secure with set screw (11).

## SUCTION VALVE

### MANUAL OPERATION

The suction side valve is designed for use as a manually operated isolation valve. This valve is not designed to automatically pivot as the discharge flappers do.

#### LOCKING:

#### WARNING

Care should be taken when performing procedures 3) and 4) below. Read the following instructions carefully.

1. Loosen suction side set screw (11) to release the locking handle (3).
2. Rotate the suction side locking handle (3) so that the handle points towards the pump to be serviced and secure in the horizontal position, using set screw (11). This releases the suction locking arm (4).

#### NOTE

THE LOCKING HANDLE (3) SHOULD ONLY BE ROTATED TOWARDS THE PUMP STOPPED FOR SERVICE. THE *dualArm* SUCTION VALVE IS DESIGNED TO PREVENT THE LOCKING HANDLE (1) FROM ROTATING TOWARDS THE RUNNING PUMP, AS THE SUCTION OF THE RUNNING PUMP COULD CAUSE THE VALVE TO SLAM SHUT WITH SUFFICIENT FORCE TO INJURE THE OPERATOR AND/OR CAUSE DAMAGE TO THE PUMP. DO NOT ATTEMPT TO CIRCUMVENT THIS SAFETY FEATURE.

- 3 Rotate the suction valve towards the pump to be isolated. The orientation of the shaft is indicated by the center pin on the locking arm (4).
4. Loosen set screw (11) and raise the locking handle (3) so that the cam on the base on the handle forces the pin of the locking arm (4) towards the pump to be isolated. The locking handle (3) should be raised to between 45 degrees and the vertical position.

**THIS HANDLE SHOULD NOT BE ROTATED PAST THE VERTICAL POSITION.**

5. Tighten set screw (11) to secure the locking handle (3) in position.

#### UNLOCKING:

#### WARNING

Care should be taken when performing procedures 3) and 4) below. Read the following instructions carefully.

1. Open the interconnecting valve on the seal flushline to pressurize the serviced pump and vent air through bleeder valve on series 4302. Close these valves once the pressure is equalized and air removed.
2. Loosen set screw (11) and lower locking handle (3) to the horizontal position, secure with set screw (11).

#### NOTE

**KEEP HANDS AND TOOLS AWAY FROM SUCTION VALVE LOCKING ARM WHEN FREED BY LOCKING HANDLE AS DIFFERENTIAL PRESSURE MAY CAUSE ARM TO ROTATE QUICKLY WITH FORCE WHEN UNLOCKED.**

3. Rotate valve to center position so that the center pin of the locking arm (4) is located in the recess on the locking handle (3).
4. Loosen set screw (11) and raise locking arm (3) to the vertical position, locking the center pin in the locking arm recess, secure with set screw.

# VALVE ILLUSTRATION (3", 4" and 6")

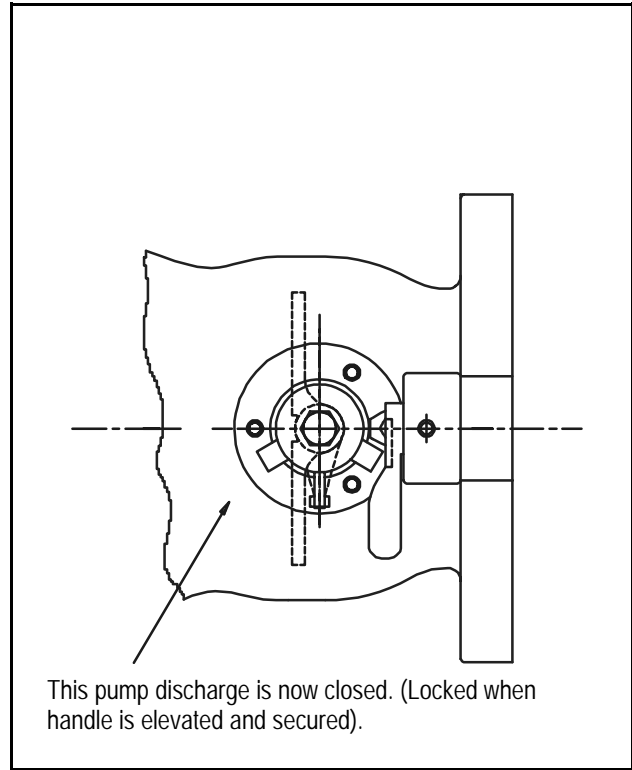
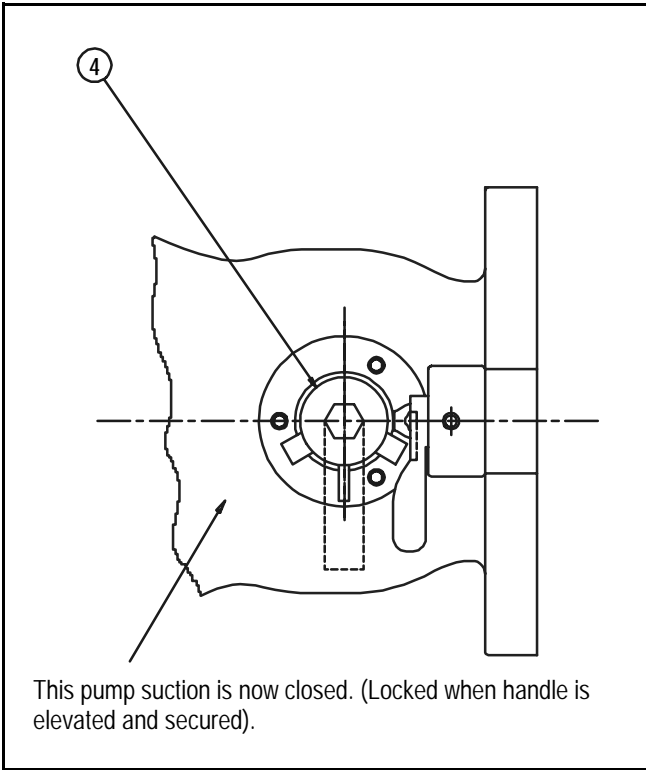

## SUCTION VALVE

## DISCHARGE VALVE

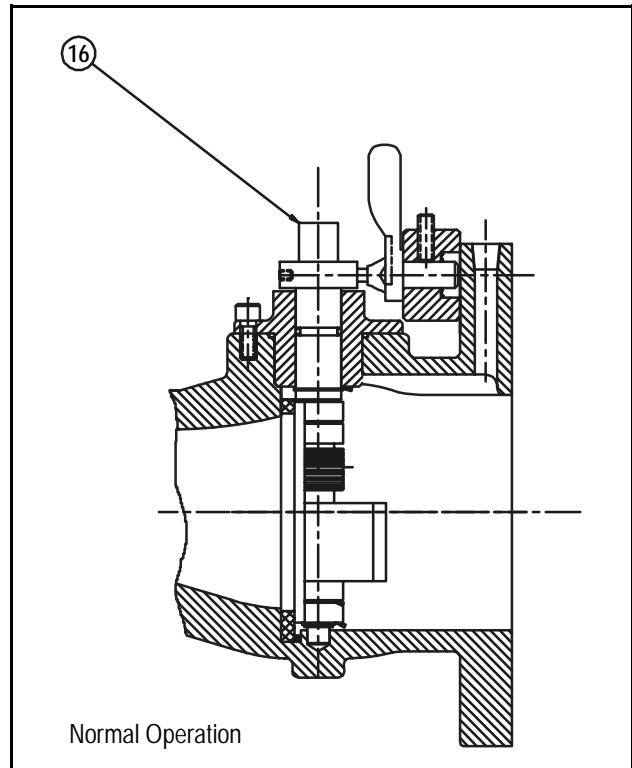
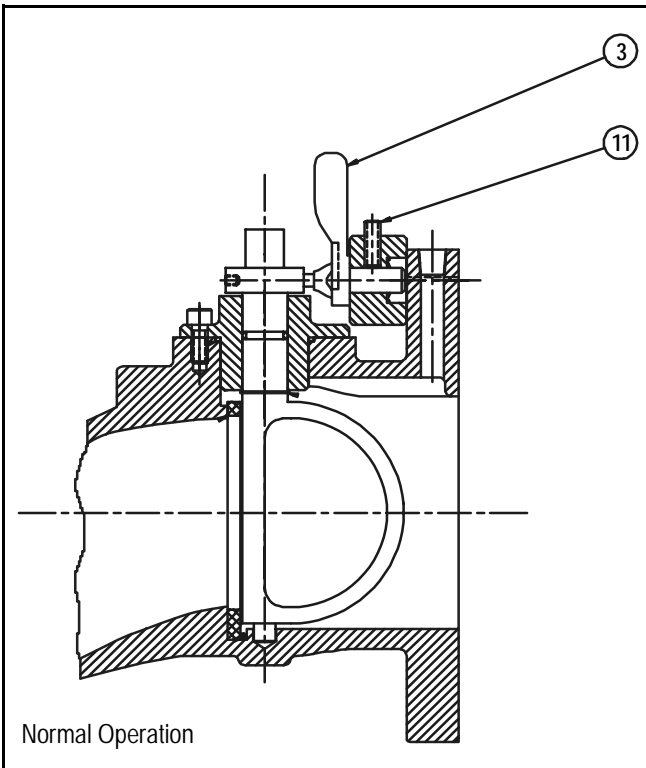

# VALVE ILLUSTRATION (8")

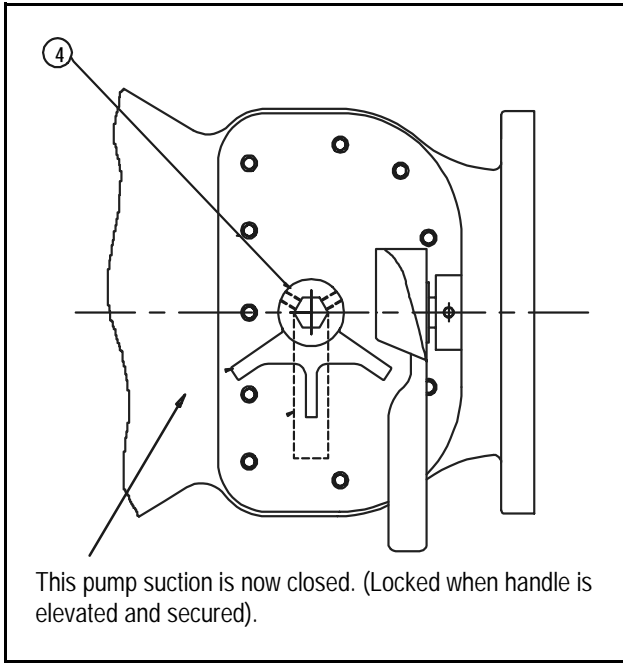

## SUCTION VALVE

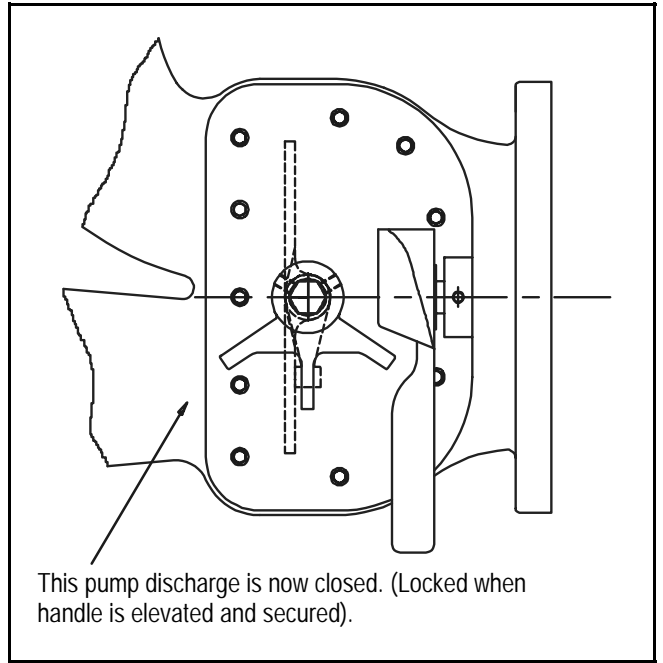
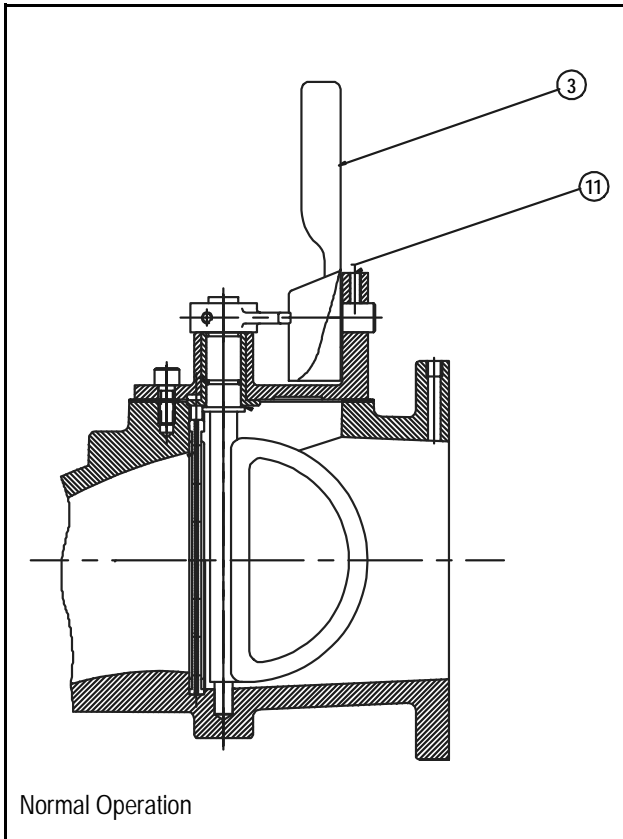

## DISCHARGE VALVE

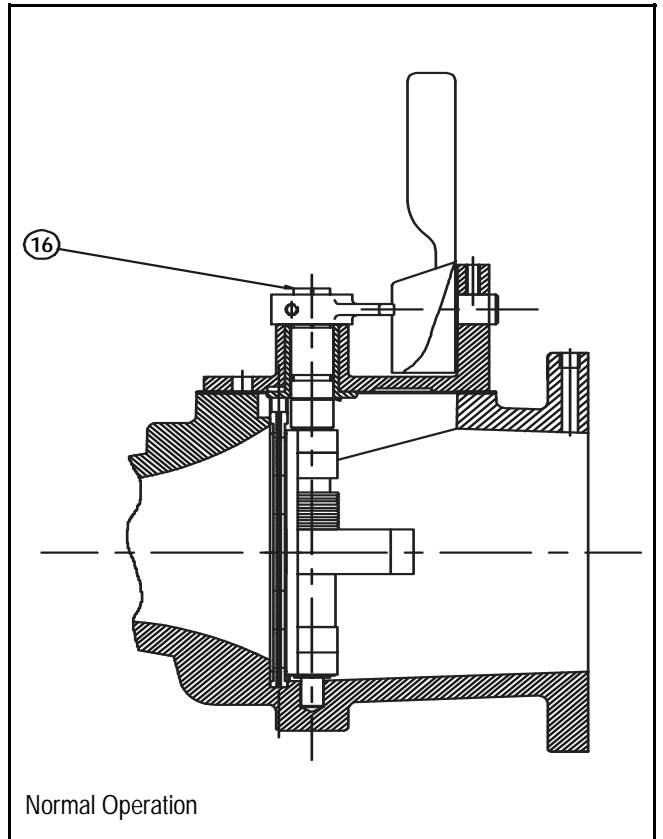

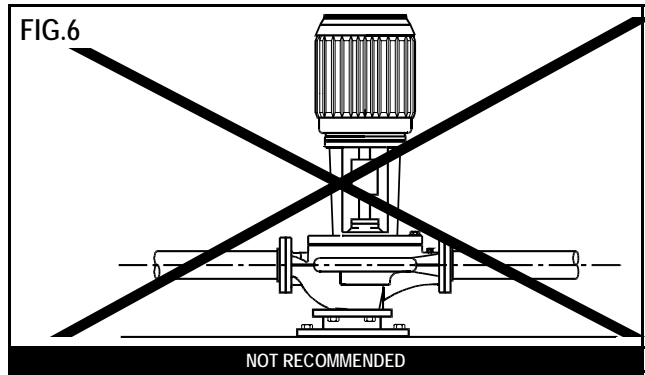
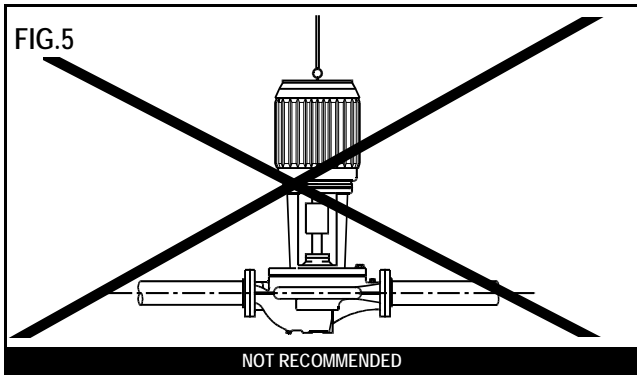
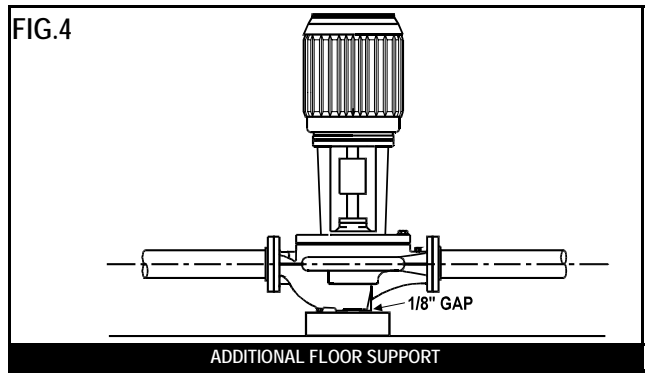
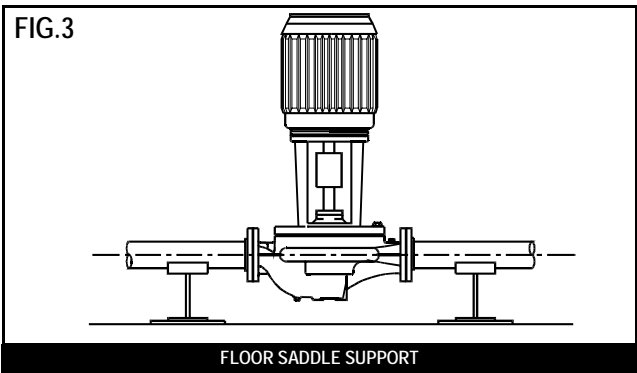
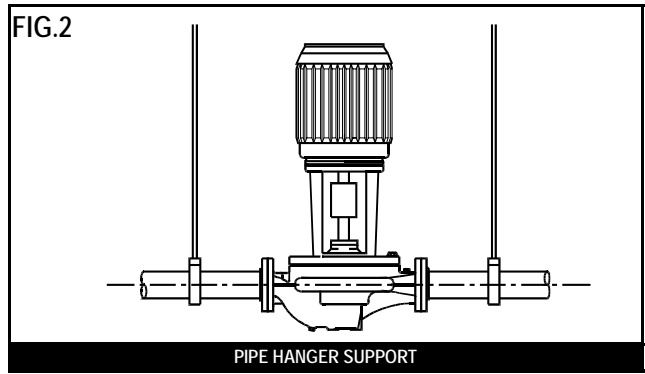
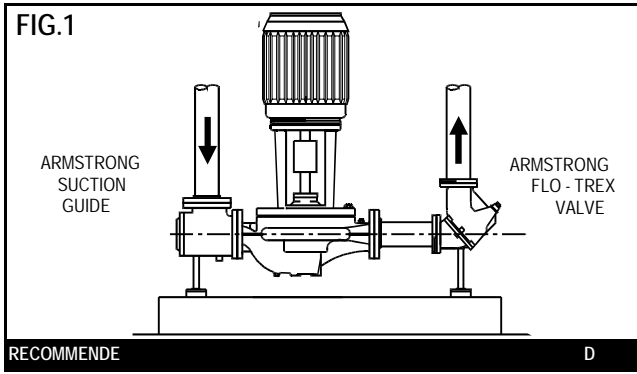

**Armstrong Pumps Inc.**  
 93 East Avenue  
 North Tonawanda, New York  
 U.S.A. 14120-6594  
 Tel: (716) 693-8813  
 Fax: (716) 693-8970  
 www.armstrongpumps.com

**Armstrong Holden Brooke Pullen**  
 Wenlock Way  
 Manchester  
 United Kingdom, M12 5JL  
 Tel: +44 (0) 1612 232223  
 Fax: +44 (0) 1612 209660



**S.A. Armstrong Limited**  
 23 Bertrand Avenue  
 Toronto, Ontario  
 Canada, M1L 2P3  
 Tel: (416) 755-2291  
 Fax: (416) 759-9101

**Armstrong Darling**  
 9001 De L'Innovation, Suite 200  
 Montreal (Anjou), Quebec  
 Canada, H1J 2X9  
 Tel: (514) 352-2424  
 Fax: (514) 352-2425

